

Wilo Suction Diffuser / Flow Diverter

Installation and operating instructions

1 Safety Instructions



Safety Instructions

This safety alert symbol will be used in this manual and on the pump safety instruction decals to draw attention to safety related instructions. When used the safety alert symbol means ATTENTION! BECOME ALERT! YOUR SAFETY IS INVOLVED! FAILURE TO FOLLOW THE INSTRUCTIONS MAY RESULT IN A SAFETY HAZARD.

2 Operational Limits

Maximum Working Pressure:
175 psi (12 bar) standard

Maximum operating Temperature:
250°F (121°C)

3 Installation Instructions

1. Before selecting a location for the pump Suction Diffuser, make sure that there is enough room provided to remove the Suction Diffuser strainer and stabilizing vanes. The length requirements are shown as Dimension "C" in the table 2.

2. If the pump pad is resilient mounted (rubber or spring), the pad should be large enough to include the adjustable Suction Diffusersupport foot.

3. Mount standard I.D. support leg and foot to pad caston body of suction diffuser. Refer to "Pipe Support" in table 2 for correct diameter.



WARNING: Potential Structural Damage Imminently Hazardous Situation!

Support leg must be installed and adjusted to support piping weight to prevent damage to Suction Diffuser and pump. Failure to follow these instructions could result in serious personal injury or death and property damage.

4. Use a criss-cross pattern when tightening the bolts. If Teflon tape is used when installing cast iron NPT Models, be careful not to overtighten the connections otherwise cracks may develop in the casting.



WARNING: Potential Gasket Leakage Imminently Hazardous Situation!

A criss-cross pattern must be used when tightening flanged joint bolts. Failure to follow these instructions could result in serious personal injury or death and property damage.



CAUTION: Potential Pipe Thread Damage

The use of Teflon impregnated pipe compound and Teflon tape on pipe threads provides lubricity which can lead to overtightening and breakage. Failure to follow these instructions could result in property damage and/or moderate personal injury.

5. Suction Diffuser blowdown is best accomplished with the system connection in the 12 o'clock position. Blowdown will be less effective with the system connection in the 3 and 9 o'clock positions.

4 Operating Instructions

1. The 20 mesh stainless steel start-up strainer must be removed from the Suction Diffuser after the initial circulation and cleaning of the system.

2. If optional pressure tap is provided, a gauge can then be connected to both the pump suction and the Suction Diffuser's schrader valve. An increase in pressure drop will indicate when the strainer may require cleaning.



CAUTION: Potential Pump Damage

Blockage in the Suction Diffuser can cause serious damage due to cavitation within the pump. NPSH requirement for the pump must be met and maintained. Check the pressure gauge installed in the Suction Diffuser periodically to prevent cavitation. Failure to follow these instructions could result in property damage and/or moderate personal injury.

5 Service Instructions

1. It is recommended that the stabilizing vanes be periodically inspected and the permanent strainer be periodically cleaned. This will ensure smooth flow into the pump and avoid damage to the pump components.



CAUTION: Potential Pump Damage

Inspect and replace damaged or corroded Suction Diffuser stabilizing vanes and orifice cylinder so that parts will not be forced into the system pump. Failure to follow these instructions could result in property damage or moderate personal injury.

2. To service and inspect the Suction Diffuser, complete the following steps:

- Shut the pump off and isolate the Suction Diffuser and pump from the system
- Allow system temperature to cool to below 100°F (38°C)



WARNING: High Temperature and Pressure Hazard Imminently Hazardous Situation!

Make sure that system temperature is below 100°F (38°C) and system pressure is reduced to and maintained at zero during servicing. Failure to follow these instructions could result in serious personal injury or death and property damage.

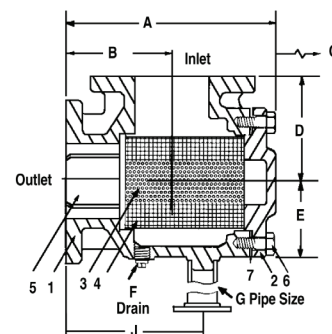

Figure 1: Cross-Section of Suction Diffuser

- Open a drain valve in the isolated Suction Diffuser piping and allow system pressure to drop to zero. If fluid continues to flow from the drain valve, repack or replace the isolation valves before proceeding.
- Loosen the screws that secure the Suction Diffuser cover and break it loose from the body. Make certain all drainage stops before removing the screws and cover.
- Grasp the stabilizing vanes with pliers and pull them out of the Suction Diffuser Body.
- Remove start-up strainer if still in place and inspect the orifice and stabilizing vanes for damage. Replace damaged components with new components as required.
- Inspect the “O” ring seal and replace with new component as required.
- Reassemble the Suction Diffuser and secure the cover with a criss-cross tightening pattern.
- Open isolation valves slowly and inspect the gasket area for leaks.
- Return system to normal operation.



WARNING: Potential Pump Damage
Imminently Hazardous Situation!

Corrosion or leakage are indications that the Suction Diffuser may be about to cause serious damage from leakage, rupture or parts entering the pump. The Suction Diffuser must be periodically inspected and if noted, the Suction Diffuser must be serviced or replaced. Failure to follow these instructions could result in serious personal injury or death and property damage.

6 Features

- Reduces both space and installation costs by replacing an extended entry pipe, a long radius elbow and a strainer
- Disposable fine mesh start-up strainer provided on all models, guarantees a clean system
- Steel stabilizing vanes ensure smooth flow into the pump
- Drain/Purge plugs furnished to routinely remove foreign particles and protect pump and other system components
- Optional pressure tap allows monitoring of strainer condition
- Blowdown tapping supplied to protect pump seals from damage by foreign particles.

Table 1: Material of Construction

1. Body:	Cast Iron
2. Cover:	Cast Iron
3. Strainers:	304 Stainless Steel
4. Start-up Strainer:	20 Mesh 304 SS Screen
5. Diffuser:	Cast Iron
6. Cap Screw:	Steel
7. Gasket/O-Ring:	Consult Factory
8. Plug:	Steel

Table 2: Dimensions of Suction Diffuser – Dimensions in inches (mm)

Part Number	Inlet/Outlet	Screen Dia. Openings	Dimensions – Inches (mm)									
			A	B	C	D	E	F (NPT)	G*	J	Width	Wt. lbs
2714200	2" x 1.5"	.13 (3.3)	9.38 (239)	4.50 (114)	8.13 (206)	4.50 (114)	2.19 (56)	.75	1	6.13 (156)	6.50 (165)	21 (9)
2714201	2" x 2"	.13 (3.3)	9.38 (239)	4.50 (114)	8.13 (206)	4.50 (114)	2.19 (56)	.75	1	6.13 (156)	6.50 (165)	23 (10)
2714202	2.5" x 2"	.13 (3.3)	10.38 (264)	5.00 (127)	9.38 (239)	5.00 (127)	3.13 (80)	.75	1	6.56 (167)	7.50 (191)	32 (14)
2714203	2.5" x 2.5"	.13 (3.3)	10.38 (264)	5.00 (127)	9.38 (239)	5.00 (127)	3.13 (80)	.75	1	6.56 (167)	7.50 (191)	34 (15)
2714204	3" x 2"	.13 (3.3)	8.38 (213)	4.25 (108)	5.00 (127)	4.69 (119)	3.13 (80)	.75	1	5.63 (143)	7.50 (191)	37 (17)
2714205	3" x 2.5"	.13 (3.3)	8.25 (210)	4.38 (111)	5.00 (127)	4.69 (119)	3.13 (80)	.75	1	5.75 (146)	7.50 (191)	49 (22)
2714206	3" x 3"	.13 (3.3)	9.38 (239)	4.75 (121)	5.25 (133)	4.75 (121)	3.63 (92)	.75	1	6.63 (168)	7.50 (191)	55 (25)
2714207	4" x 3"	.13 (3.3)	9.38 (239)	4.75 (121)	5.25 (133)	5.63 (143)	3.63 (92)	.75	1	6.63 (168)	9.00 (229)	57 (26)
2714208	4" x 4"	.13 (3.3)	11.13 (283)	5.75 (146)	6.34 (161)	5.75 (146)	4.25 (108)	.75	1.25	7.63 (194)	9.00 (229)	92 (42)
2714209	5" x 4"	.13 (3.3)	11.13 (283)	5.75 (146)	6.34 (161)	6.63 (168)	4.25 (108)	.75	1.25	7.63 (194)	10.00 (254)	97 (44)
2714210	5" x 5"	.13 (3.3)	12.63 (321)	6.50 (165)	7.13 (181)	6.50 (165)	4.88 (124)	1	1.25	8.63 (219)	10.00 (254)	101 (46)
2714211	6" x 4"	.13 (3.3)	11.13 (283)	5.75 (146)	6.34 (161)	7.50 (191)	4.25 (108)	.75	1.25	7.75 (197)	11.00 (279)	104 (48)
2714212	6" x 5"	.13 (3.3)	12.63 (321)	6.50 (165)	7.13 (181)	7.38 (188)	4.88 (124)	1	1.25	8.63 (219)	11.00 (279)	145 (66)
2714213	6" x 6"	.13 (3.3)	13.88 (353)	7.00 (178)	7.88 (200)	7.00 (178)	5.88 (149)	1	2	9.13 (232)	11.00 (279)	182 (83)
2714214	8" x 6"	.13 (3.3)	13.88 (353)	7.00 (178)	7.88 (200)	8.75 (222)	5.88 (149)	1	2	9.13 (232)	13.50 (343)	197 (89)
2714215	8" x 8"	.13 (3.3)	18.88 (480)	9.25 (235)	16.25 (413)	9.25 (235)	6.38 (162)	1	2	11.63 (295)	13.50 (343)	292 (132)
2714216	10" x 8"	.13 (3.3)	18.88 (480)	9.25 (235)	16.25 (413)	11.00 (279)	6.38 (162)	1	2	11.63 (295)	16.00 (406)	312 (142)
2714217	10" x 10"	.13 (3.3)	23.88 (607)	11.00 (279)	16.13 (410)	11.25 (286)	8.00 (203)	1	2	13.75 (349)	16.00 (406)	398 (181)
2714218	12" x 8"	.13 (3.3)	18.88 (480)	9.25 (235)	16.25 (413)	12.00 (305)	6.38 (162)	1	2	11.63 (295)	19.00 (483)	412 (187)
2714219	12" x 12"	.13 (3.3)	23.88 (607)	11.00 (279)	16.13 (410)	12.00 (305)	8.00 (203)	1	2	13.75 (349)	19.00 (483)	491 (223)
2714220	12" x 12"	.13 (3.3)	26.00 (660)	12.00 (305)	18.13 (461)	12.00 (305)	9.25 (235)	1	2	13.88 (353)	19.00 (483)	573 (260)

* Pipe Support supplied by contractor

Wilo USA LLC

Tel: 888-945-6872
Fax: 888-945-6873
Email: info@wilo-usa.com
Web: www.wilo-usa.com

Wilo Canada Inc.

Tel: 866-945-6236
Fax: 403-277-9456
Email: info@wilo-canada.com
Web: www.wilo-canada.com

