

Three and a Half Decades of EMU in the USA:

A History of Value and Performance

Almost thirty-five years ago, the first EMU submersible sewage pumps arrived on American shores. At first, little notice was paid to these bright orange pumping machines, but—as time passed and experience grew—the popularity of EMU submersible pumps grew into a "following", and from there into an industry legend.

The Secret was Staying Cool

EMU engineers recognized, early on, that the proper management of the heat generated from the operation of the pump motor was key to the preservation of the pumps internal components. This focus on thermal



EMU engineers recognized, early on, that the proper management of the heat generated from the operation of the pump motor was key to the preservation of the pumps internal components.

interactions—as well as friction related issues—resulted in the development of pumping equipment that proved to be highly reliable and extremely durable—even over very long periods of time (often measured in decades).

In 1971, the first EMU pumps made available to the U.S. marketplace were offered through a distribution agreement with Pollution Equipment Control, a subsidiary of B & H Sales and Certainteed Corporation, located in Orlando, Florida.

Within a year, several early adopters of EMU pump technology had new EMU's up and running. This group included: Adel, Georgia; Sebring, Florida; and Manatee County, Florida.

Just five years later, in 1976, EMU introduced a submersible pump equipped with a two hundred horsepower motor to the U. S. marketplace, amazing those attending the WPCF show in Denver, Colorado—the site of its unveiling.

Bringing the Benefits of Dry Pit Pumps to the U.S.

The use of dry pit pumps became popular in Europe because not only were they amazingly reliable but they were much easier to monitor, maintain, change-out, etc. (because they were not submerged). In fact, by the 1960's dry pit pumps were quickly becoming the standard in Western Europe. Most pump

manufacturers, at the time, were dependent on submersion, for heat transfer. (EMU pump motors—cooled by an internal circulation system that transferred heat to the pumped liquid—did not require submersion.)

Soon after EMU introduced dry pit pumps in the U.S., in 1977, Centralia, Illinois chose to go with EMU dry pit pumping technology, with the installation of a sizable 120 horsepower model. Since then, EMU dry pit pumps have been installed in every type of application. In 1991, the largest dry pit pump in the world (at the time) was installed at Portsmouth, New Hampshire. It provided a whopping 450 horsepower worth of pumping power.



EMU dry pit pumps are very popular because they can endure in almost any environment.

Decades of Service and Reliability from the WILO EMU U.S.A. Team

EMU Availability Expanded When Davis Industries Took Over Distribution Duties in the U.S.

In 1979, EMU shifted the responsibility of U.S. distribution to Davis Water & Waste Industries, Inc. Davis Industries was located in Thomasville, Georgia, but continued to maintain an EMU related facility in Orlando, Florida. (In the first year of Davis Industries distribution activities, shipments totaled just \$61,354 and employed just four people.) In 1980, EMU offices were moved from Orlando, Florida to Thomasville, Georgia.

At this point, the shipment and installation of EMU pumps grew steadily, as did their reputation.

Simply, day-to-day use proved their value and word began to spread from city to city.

In 1985, EMU Mixers Were Introduced in America

As with EMU's pump technologies, the quality and value inherent in EMU's submersible mixers began to draw the attention of industry professionals. In fact, in 1989, forty-eight mixers were installed at Inland Empire, California, alone. (During this same period, in 1988, EMU opened it's first branch operation in Dallas, Texas.)

Soon, many of the industry's major facilities signed up for EMU mixers, as well as EMU pumps. For example: in 1995, New York City installed over 250 EMU mixers at various plant sites in the metropolitan area. Three years

later, Atlanta's R.M. Clayton WWTP—the largest wastewater treatment plant this side of Washington, DC—installed 114 EMU mixers. EMU mixers were a hit, because, like the pumps that preceded them into the U.S. marketplace, they delivered measurable value.

USFilter Signs on to Distribute EMU Pumping and Mixing Technologies

After the acquisition of Davis Water & Waste Industries, Inc., USFilter became the distributor for EMU Pumps and Mixers in the U.S. About a year later, an EMU branch was added in Temecula, California to serve growing demand on the west coast.

Over the next six years, growth continued for both pumps and mixers and spread into every sector of the industry.

At this point, it was common to hear stories of EMU pumps—that had been in continuous service at U.S. facilities for fifteen years or more—being disassembled to reveal virtually

no wear on the internal components or surfaces. There have been many stories of the heroic capabilities of EMU mixers, also. Suffice it to say, EMU pumps and mixers are now the stuff of legends, but their real benefits do turn out to be very tangible.

Into the Future, With WILO AG

In 2003, WILO AG, one of the world's leading pump manufacturers purchased EMU GmbH and through mutual agreement ended the distribution arrangement with USFilter (now known as Siemens Water Technologies). WILO EMU, in turn determined that the U.S. marketplace deserved a much larger commitment of resources, and on January 1, 2005, established WILO-EMU USA LLC as a subsidiary of WILO Nord America.

Within months, a major Service Center was established and expansion plans were drawn up for the U.S. headquarters facility in Thomasville, Georgia.

According to Terry Rouse, President and CEO of WILO-EMU USA LLC, "We are looking forward to greatly expanding our presence in the U.S. marketplace, while continuing to bring exceptional value in both service and products to our customers. For example, we have just introduced the new HC motor technology into America and can easily say that this is the most significant advance in pump motor technology in recent decades. Also, we have dramatically expanded our on-site 24/7 service program—just in the last six months. Today, as it has been for the last thirty-five years, there is no better pump or mixer value in American than the WILO EMU."

Also, Mr. Rouse added, "I am proud that many of the earliest members of the EMU U.S. team still play active and key roles in the service and support of our customers. I think that is what happens when you have a product that you can really believe in and one that you can be proud of thirty-five years later."

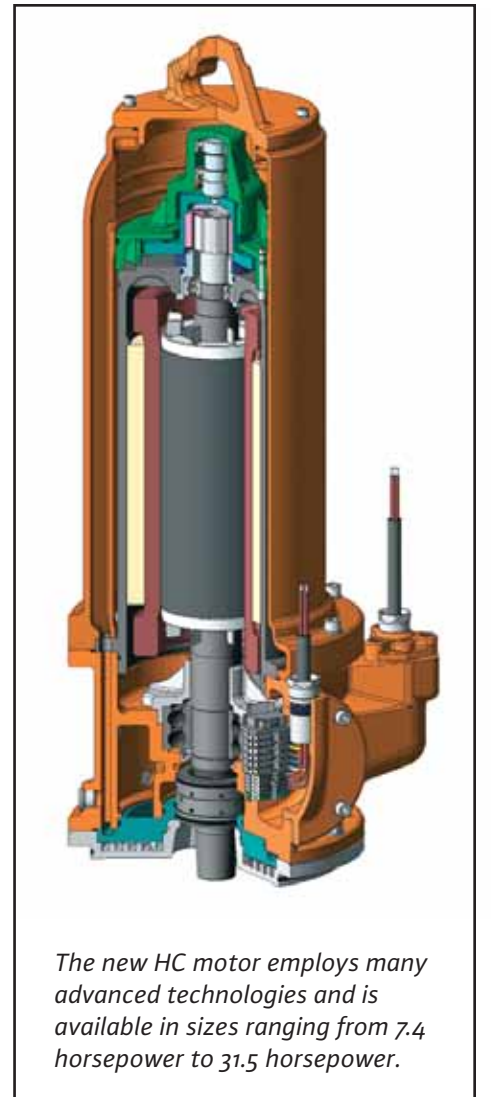

The new HC motor employs many advanced technologies and is available in sizes ranging from 7.4 horsepower to 31.5 horsepower.

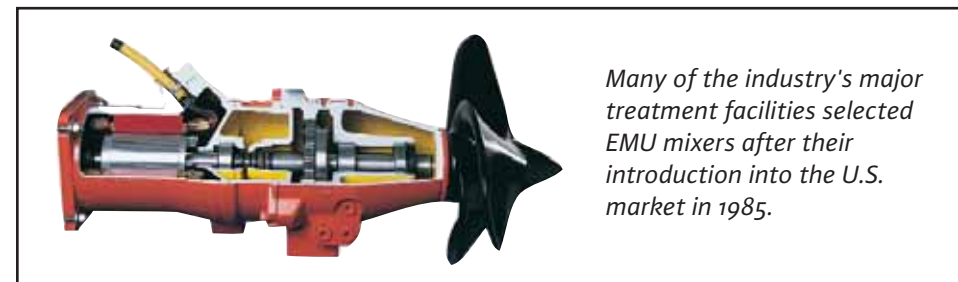

Many of the industry's major treatment facilities selected EMU mixers after their introduction into the U.S. market in 1985.

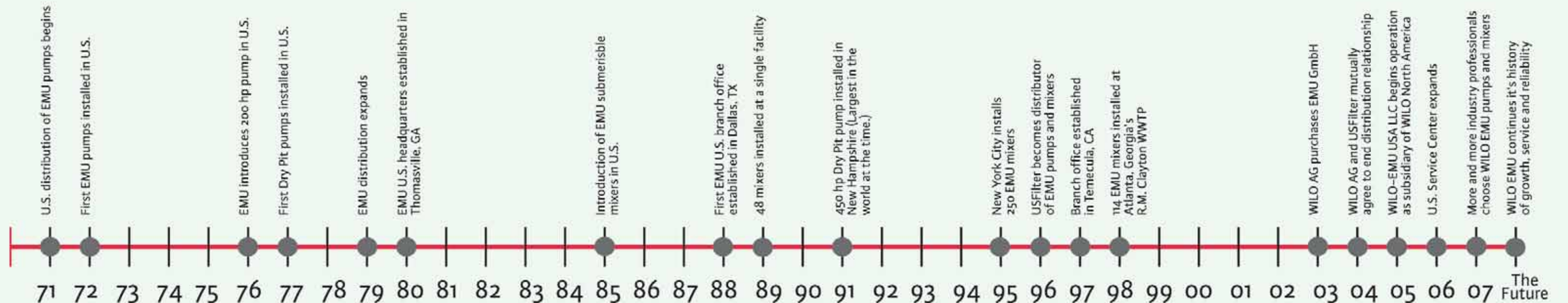

WILO EMU
Pumpen Intelligenz.

WILO-EMU USA LLC
Post Office Box 7810
Thomasville, GA 31758-7810
170 Big Star Drive
Thomasville, GA 31757

Toll Free Phone: 866-467-0323
Toll Free Fax: 866-293-4348

E-mail: info@wilo-emu-usa.com
Website: www.wilo-emu-usa.com

One Call Does It All: 1-866-476-0323

**Comprehensive On-Site Service for
Pumps and Mixers**

